

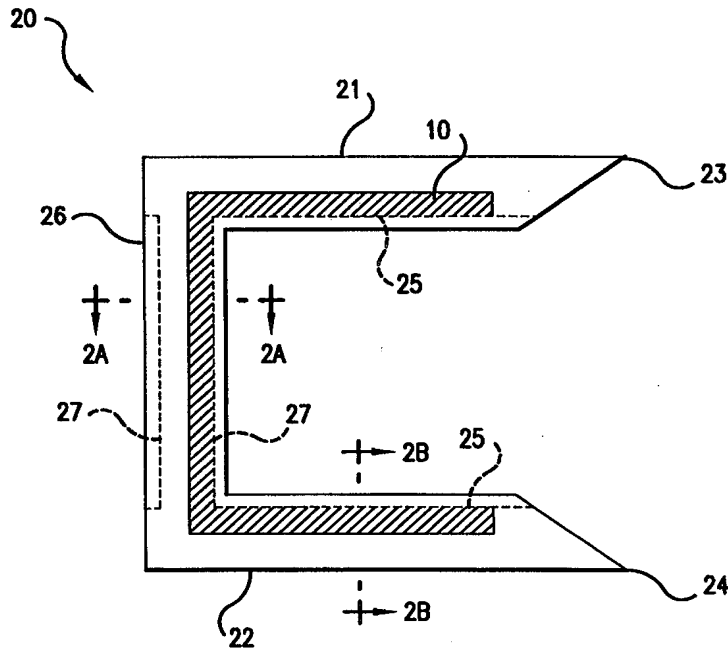

INTERNATIONAL APPLICATION PUBLISHED UNDER THE PATENT COOPERATION TREATY (PCT)

<p>(51) International Patent Classification ⁶ : A61B 17/122, 17/128</p>	<p>A1</p>	<p>(11) International Publication Number: WO 98/58591 (43) International Publication Date: 30 December 1998 (30.12.98)</p>
<p>(21) International Application Number: PCT/US98/12552 (22) International Filing Date: 17 June 1998 (17.06.98) (30) Priority Data: 08/879,931 20 June 1997 (20.06.97) US (71) Applicant: BOSTON SCIENTIFIC CORPORATION [US/US]; One Boston Scientific Place, Natick, MA 01760 (US). (72) Inventor: ADAMS, Ronald; 18 Hillside Drive, Holliston, MA 01746 (US). (74) Agents: BRAINARD, Charles, R. et al.; Kenyon & Kenyon, 1025 Connecticut Avenue, N.W., Washington, DC 20036 (US).</p>		<p>(81) Designated States: AL, AM, AT, AU, AZ, BA, BB, BG, BR, BY, CA, CH, CN, CU, CZ, DE, DK, EE, ES, FI, GB, GE, GH, GM, GW, HU, ID, IL, IS, JP, KE, KG, KP, KR, KZ, LC, LK, LR, LS, LT, LU, LV, MD, MG, MK, MN, MW, MX, NO, NZ, PL, PT, RO, RU, SD, SE, SG, SI, SK, SL, TJ, TM, TR, TT, UA, UG, UZ, VN, YU, ZW, ARIPO patent (GH, GM, KE, LS, MW, SD, SZ, UG, ZW), Eurasian patent (AM, AZ, BY, KG, KZ, MD, RU, TJ, TM), European patent (AT, BE, CH, CY, DE, DK, ES, FI, FR, GB, GR, IE, IT, LU, MC, NL, PT, SE), OAPI patent (BF, BJ, CF, CG, CI, CM, GA, GN, ML, MR, NE, SN, TD, TG).</p> <p>Published <i>With international search report.</i></p>

(54) Title: HEMOSTATIC CLIPS



(57) Abstract

Clips having pseudoelastic properties at body temperature are used to cause hemostasis of blood vessels located along the gastrointestinal tract. Methods for causing the hemostasis of blood vessels and ulcer beds using the clips of the present invention are also disclosed.

FOR THE PURPOSES OF INFORMATION ONLY

Codes used to identify States party to the PCT on the front pages of pamphlets publishing international applications under the PCT.

AL	Albania	ES	Spain	LS	Lesotho	SI	Slovenia
AM	Armenia	FI	Finland	LT	Lithuania	SK	Slovakia
AT	Austria	FR	France	LU	Luxembourg	SN	Senegal
AU	Australia	GA	Gabon	LV	Latvia	SZ	Swaziland
AZ	Azerbaijan	GB	United Kingdom	MC	Monaco	TD	Chad
BA	Bosnia and Herzegovina	GE	Georgia	MD	Republic of Moldova	TG	Togo
BB	Barbados	GH	Ghana	MG	Madagascar	TJ	Tajikistan
BE	Belgium	GN	Guinea	MK	The former Yugoslav Republic of Macedonia	TM	Turkmenistan
BF	Burkina Faso	GR	Greece			TR	Turkey
BG	Bulgaria	HU	Hungary	ML	Mali	TT	Trinidad and Tobago
BJ	Benin	IE	Ireland	MN	Mongolia	UA	Ukraine
BR	Brazil	IL	Israel	MR	Mauritania	UG	Uganda
BY	Belarus	IS	Iceland	MW	Malawi	US	United States of America
CA	Canada	IT	Italy	MX	Mexico	UZ	Uzbekistan
CF	Central African Republic	JP	Japan	NE	Niger	VN	Viet Nam
CG	Congo	KE	Kenya	NL	Netherlands	YU	Yugoslavia
CH	Switzerland	KG	Kyrgyzstan	NO	Norway	ZW	Zimbabwe
CI	Côte d'Ivoire	KP	Democratic People's Republic of Korea	NZ	New Zealand		
CM	Cameroon			PL	Poland		
CN	China	KR	Republic of Korea	PT	Portugal		
CU	Cuba	KZ	Kazakistan	RO	Romania		
CZ	Czech Republic	LC	Saint Lucia	RU	Russian Federation		
DE	Germany	LI	Liechtenstein	SD	Sudan		
DK	Denmark	LK	Sri Lanka	SE	Sweden		
EE	Estonia	LR	Liberia	SG	Singapore		

HEMOSTATIC CLIPS

Field of the Invention

The present invention relates to hemostatic clips,
5 and more specifically, to pseudoelastic nitinol clips
which are used to cause hemostasis of blood vessels
located along the gastrointestinal tract.

Background of the Invention

10 Gastrointestinal bleeding is a somewhat common and
serious condition that can be fatal if left untreated.
This problem has prompted the development of a number of
endoscopic therapeutic approaches to achieve hemostasis,
such as the injection of sclerosing agents and contact
15 thermo-coagulation techniques. Although such approaches
can be effective, bleeding often continues for many
patients and corrective surgery therefore becomes
necessary. Because surgery is an invasive technique that
can be associated with many undesirable side effects,
20 there exists the need for highly effective, less invasive
procedures.

Mechanical hemostatic devices have been used in
various parts of the body, including gastrointestinal
applications. Such devices are typically in the form of
25 clamps, clips, staples, sutures, etc. which are able to
apply sufficient constrictive forces to blood vessels so
as to limit or interrupt blood flow. One of the
problems associated with conventional hemostatic devices,
however, is that they can only be delivered using rigid-
30 shafted instruments via incision or trocar cannula.
Moreover, none of the conventional endoscopic hemostatic

devices are strong enough to cause permanent hemostasis.

In order to avoid the problems associated with conventional hemostatic devices, the use of shape memory alloys has been proposed. For example, U.S. Patent No. 4,485,816, hereby incorporated by reference, discloses the use of a shape memory surgical staple for use in holding the edges of a wound together while it heals. Similarly, U.S. Patent No. 5,002,563, hereby incorporated by reference, discloses the use of shape memory sutures.

10

Shape memory alloys (SMA's) have the ability to "remember" specific shapes which corresponds to particular metallurgical phases. If deformed, SMA's can be heated or cooled to invoke a phase transformation, which in turn, causes a transformation in shape. Shape memory alloys are characterized by a transition temperature or transition temperature range, above which the predominant metallurgical phase is termed austenite and below which the predominant phase is termed martensite. The transformation temperatures of SMA's are commonly discussed with reference to M_s and M_f , the martensitic start and finish temperatures, respectively, and A_s and A_f , the austenitic start and finish temperatures, respectively. The transformation between these phases is reversible such that when alloys are deformed into some first configuration while in the austenitic state, cooled into a martensitic state, deformed into a second configuration, and then re-heated to the austenitic state, the alloy will revert back to the first configuration by virtue of the martensite-to-austenite phase transformation.

20

PCT Publication No. WO 96/16603, hereby incorporated by reference, specifically discloses the use of shape memory materials to address the problem of gastrointestinal bleeding. In this reference, a hemostatic staple is employed to affect hemostasis of an actively bleeding peptic ulcer. The staple makes use of

35

the thermally-induced martensite-to-austenite transformation in shape memory nickel-titanium alloys ("nitinol"), thus requiring the application or removal of heat to the staple for deployment. One of the problems with this and similar SMA devices is that the change in temperature necessary to induce the required shape change can be procedurally difficult, and more importantly, can put the nearby tissue and surgical instrumentation at risk. In addition, it can be difficult to manufacture SMA's with the precise transformation temperatures necessary for surgical applications. It is therefore necessary to carefully monitor the temperature of such devices during shipping and storage so as to avoid phase transformations during this time. Moreover, the thermally-induced phase change may not produce forces adequate to hemostatically close vessels or compress tissue.

The use of nitinol alloys having the ability to form stress-induced martensite as opposed to thermally-induced martensite has been used in medical devices so as to avoid the potential problems of SMA devices. In such alloys, the reversible transformation between martensite and austenite occurs by the application and removal of stress rather than heat. Such alloys are characterized by an M_d temperature, which is greater than A and represents the maximum temperature at which stress-induced martensite can form. By deforming these alloys at a temperature between A_s and M_d , the alloy transforms from its austenitic phase to a stress-induced martensitic phase. Upon release of the stress within this temperature range, the alloy reverts back to its austenitic phase and unstressed configuration. The property of nitinol which allows it to be deformed in its austenitic state so to cause a transformation to stress-induced martensite that is transformed back to austenite by the release of stress is often termed "pseudoelasticity." Strains of 8% or more are obtained in

pseudoelastic nitinol, thus making this material useful for a wide range of applications where a large amount of recoverable deformation is required.

U.S. Patent No. 4,665,906, incorporated herein by
5 reference, describes some medical devices which make use of pseudoelastic nitinol. In such devices, austenitic nitinol is deformed to form stress-induced martensite and held in its deformed configuration and martensitic state by a restraining member. In this condition, the device
10 is introduced into the body, where it is removed from the restraining member to return to its austenitic state and configuration.

Summary of the Invention

15 The present invention is directed to hemostatic clips which exhibit pseudoelastic properties at body temperature. The clips of the present invention are able to compress tissue to cause the hemostasis of bleeding blood vessels, particularly gastrointestinal bleeders.
20 In one embodiment of the present invention, the clips have a "U"-shaped configuration when in an undeformed state. In a second embodiment of the present invention, the clips have a circular-shaped configuration when in an undeformed state. The present invention includes methods
25 and systems for causing the hemostasis of blood vessels and ulcer beds located along the gastrointestinal tract using hemostatic clips.

One advantage of the present invention is that it provides a reliable, definitive treatment for the problem
30 of gastrointestinal bleeding.

Another advantage of the present invention is that it can be delivered via natural body orifices for the control of gastrointestinal bleeding.

Another advantage of the present invention is that
35 it provides hemostatic clips which are deployed without the application or removal of heat.

Yet another advantage of the present invention is

that it provides hemostatic clips with sufficient strength to produce permanent hemostasis when deployed.

Another advantage of the present invention is that it provides hemostatic clips which are particularly designed for application to gastrointestinal bleeders.

Brief Description of the Drawings

Figs. 1A and 1B are plan views of a U-shaped hemostatic clip in a first and second configuration, respectively, in accordance with the present invention.

Fig. 2 includes plan and cross-sectional views of a hypotube of the present invention.

Figs. 3-5 illustrate a method of deploying the hemostatic U-shaped clips of the present invention.

Fig. 6 is a plan view showing an ulcer bed surrounded by hemostatic clips, in accordance with the present invention.

Figs. 7A and 7B are plan and end views, respectively, of a delivery device used to deploy the U-shaped hemostatic clips of the present invention.

Fig. 7B is a plan view of a delivery device deploying the hemostatic clips of the present invention adjacent an ulcer bed.

Figs. 8A and 8B are plan views of circular hemostatic clips of the present invention.

Fig. 9 is a plan view of a hypodermic needle of the present invention.

Fig. 10 is a plan view of a delivery device used to deploy the circular hemostatic clips of the present invention.

Figs. 11A-11D illustrate a method of deploying the hemostatic circular clips of the present invention.

Detailed Description

The present invention is designed to address the problems encountered in conventional methods used to ligate blood vessels. More particularly, the present

invention is adapted to restrict blood flow which results in gastrointestinal bleeding.

The present invention includes hemostatic clips which make use of pseudoelastic properties found in materials such as nitinol. Using these properties, the clips of the present invention are shaped into a first configuration that is useful for ligating blood vessels, deformed to a second configuration to facilitate placement to a desired location within the body, and released from its deformed configuration to allow a spontaneous reversion towards the first configuration.

The pseudoelastic material used to make the hemostatic clips of the present invention is characterized by an A_s temperature less than body temperature and an M_d temperature greater than body temperature. A clip in accordance with the present invention is thus provided with a first configuration in its austenitic state, which is deformed to a second configuration to facilitate the placement of the clip around or adjacent to a bleeding blood vessel. The deformation of the clip from its first configuration to its second configuration results in the formation of stress-induced martensite. The clip is held in its second configuration until positioned to a target location along the gastrointestinal tract. When released from this second configuration, the clip is urged toward its austenitic state and corresponding first configuration because A_s is less than body temperature and austenite is therefore the stable metallurgical phase. In this way, the clip applies sufficient constrictive forces to the bleeding blood vessel to cause hemostasis thereof.

The hemostatic clips of the present invention are of any suitable configuration. In a first embodiment of the present invention as shown in Fig. 1, however, hemostatic clip 10 is in the form of a U-shaped wire having first 11 and second 12 prongs, and rear member 13. The diameter

or width of rear member is less than that of either of the first 11 or second 12 prongs. The first configuration of clip 10 as shown in Fig. 1A represents the shape of clip 10 when in its substantially austenitic state. In this configuration, the distance between said first 11 and second 12 prongs is about 5-10 millimeters, preferably about 7 millimeters. This dimensional range is specifically designed to address the problem of gastrointestinal bleeders. The cross-section of clip 10 is preferably circular, although other cross-sectional shapes such as rectangular can be used.

To facilitate placement around or near a blood vessel, prongs 11 and 12 are urged in an outward direction to achieve a second configuration as shown in Fig. 1B. The distance between prongs 11 and 12 in this second configuration can be up to 15 millimeters or more.

When deformed into the shape shown in Fig. 1B from the shape shown in Fig. 1A, U-shaped clip 10 undergoes at least a partial stress-induced transformation from austenite to martensite.

A device such as hypotube 20, as shown in Fig. 2, is used to hold U-shaped clip 10 in its second configuration while it is delivered to a target location along the gastrointestinal tract. Hypotube 20 is made of any suitable material, such as stainless steel.

Hypotube 20 includes first 21 and second 22 prongs having pointed ends 23 and 24, respectively. Along the length of the inner sides of first 21 and second 22 prongs are longitudinal slots 25. Along the length of both sides of rear member 26 are transverse slots 27. The width of slots 26 and 27 are wider than the width of rear member 13 of U-shaped clip 10, yet more narrow than first 11 and second 12 prongs of U-shaped clip 10. Such a configuration allows hypotube 20 to hold U-shaped clip 10 in its second configuration, while permitting the passage of U-shaped clip 10 through hypotube 20.

After placing clip 10 in hypotube 20, it is inserted

as part of a delivery device 30 into the gastrointestinal tract, preferably via a natural body orifice. Upon reaching a target location, the pointed ends 23 and 24 of hypotube 20 are used to penetrate the gastrointestinal wall 31 by advancing a first pusher bar 32 which is
5 attached to hypotube 20, as shown in Fig. 3. Also shown in Fig. 3 is second pusher bar 33, which rests against, but is not attached to, clip 10. Second pusher bar 33 is inserted through transverse slots 27 of hypotube 20 to
10 contact clip 10. The length of prongs 21 and 22 are sufficient to ensure that the blood vessel to be treated is positioned between the prongs 11 and 12 of clip 10, or is within about one centimeter of the ends of prongs 11 and 12 of clip 10. The rear member 26 of hypotube 20
15 remains outside of the gastrointestinal wall.

To deploy clip 10, hypotube 20 is withdrawn from the gastrointestinal wall 31 by retracting first pusher bar 32, as shown in Fig. 4. During the withdrawal of
20 hypotube 20, second pusher bar 33 remains extended so to keep clip 10 at the target location. As clip 10 is released from hypotube 20, it is urged towards its austenitic configuration as shown in Fig. 4. When hypotube 20 is completely withdrawn from the
25 gastrointestinal wall 31, the contact between second pusher bar 33 and clip 10 is broken as shown in Fig. 5.

The clips of the present invention are delivered by any suitable instrumentation, as is known in the art. For delivery of the clips via natural body orifices,
30 which is the preferred method of delivery, it is usually necessary to deliver the clips with the aid of steerable endoscope to allow the physician installing the clips to visually examine the target location. "Endoscope" is intended to include similar instrumentation such as a gastroscop
35 or duodenoscope.

In addition to causing the hemostasis of individual blood vessels, the present invention contemplates the use of hemostatic clips to cause the hemostasis of bleeding

ulcer beds. In order to achieve the hemostasis of an ulcer bed, it is desirable to substantially surround the ulcer bed 60 with hemostatic clips 62, as shown in Fig. 6. This is preferably achieved with two pairs of hemostatic clips 62, each pair being substantially parallel to each other yet orthogonal to the other pair. The hemostatic clips 62 are deployed into the gastrointestinal wall 61 in the configuration shown in Fig. 6 so to reduce the flow of blood to ulcer bed 60. Each of the clips 62 should be within about 5 mm, preferably about 2 mm, and most preferably about 1 mm from the edge of ulcer bed 60.

In order to achieve the configuration of clips shown in Fig. 6, it is necessary to manipulate the clip delivery device to properly orient the clips prior to insertion. This can be done with steerable endoscopes, as are known in the art, provided that the clips are deployed in regions of the gastrointestinal tract that are wide enough to permit such manipulation (e.g., the stomach or lower bowel). In narrow regions of the gastrointestinal tract (e.g., the duodenum), however, it may be necessary to use a delivery device in which the clips are pre-loaded in the proper orientation. An example of such a device is shown in Figs. 7A-7C. As shown in Fig. 7A, delivery device 70 comprises an endoscope 71 having a sheath 72 ending in a collar 73 that houses the hemostatic clips. As shown in Fig. 7B, the clips 10 are oriented for the deployment configuration as shown in Fig. 6. As is known in the art, endoscope 71 includes optics 74 and at least one light 75. Sheath 72 is used to house any wires, instrumentation, etc. necessary to deploy clips 10 from collar 73. In addition, sheath 72 is optionally slidable about endoscope 71 to permit rotation of collar 73 and the corresponding axial positioning of clips 10. Although U-shaped clips 10 are shown in Fig. 7B, collar 73 is easily adapted for the deployment of hemostatic

clips having a circular or other configuration. To
deploy clips 10, endoscope 71 is oriented so that the
surface of collar 73 is adjacent the gastrointestinal
wall 61 as shown in Fig. 7C. Clips 10 are thereafter
5 inserted into the gastrointestinal wall 61 so as to
substantially surround ulcer bed 60 in an arrangement as
shown in Fig. 6.

In another embodiment of the present invention, the
nitinol hemostatic clip of the present invention is in a
10 substantially circular configuration when it is in a
substantially austenitic state, as shown in Fig. 8.
Circular clip 80 has a diameter of about 5-10
millimeters, and preferably about 7 millimeters when in
its austenitic configuration. This dimensional range is
15 specifically designed to address the problem of
gastrointestinal bleeders. Circular clip 80 can have
interlocking or adjoining ends 81, 82, as shown in Fig.
8A, or overlapping ends as shown in Fig. 8B.

To facilitate placement around or near a blood
20 vessel, the ends of circular clip 80 are urged away from
each other so that clip 80 achieves some second
configuration that permits clip deployment. This second
configuration typically has a straightened or arc shape.
When deformed into this second configuration, circular
25 clip 80 undergoes at least a partial stress-induced
transformation from austenite to martensite.

A device such as hypodermic needle 90, as shown in
Fig. 9, is used to hold circular clip 80 in its second
configuration while it is delivered to a target location
30 along the gastrointestinal tract. Hypodermic needle has
an arc configuration and includes pointed end 91, base 92
and pusher bar 93. Hypodermic needle 90 is made of any
suitable material, although stainless steel is preferred.

Circular clip 80 is delivered to a target location
35 along the gastrointestinal tract by any suitable
instrumentation, as is known in the art. Circular clip
80 is preferably delivered with the delivery device shown

in Fig. 10. Delivery device 100 includes a duodenoscope 101 having side-mounted optics 102, at least one side-mounted light 103 and grasper 104. Sheath 105, ending in collar 106, covers only part of the circumference of duodenoscope 101 so as not to cover the optics 102, light 103 or grasper 104.

Delivery device 100 is used to deliver circular clip 80 by the method shown in Figs. 11A-11D. As shown in Fig. 11A, the delivery device 100 is delivered to a target location along the gastrointestinal tract. Grasper 104 is used to grasp the gastrointestinal wall 31 and pull it towards the duodenoscope 101. As shown in Fig. 11B, hypodermic needle 90 penetrates the pulled portion of the gastrointestinal wall and is advanced to a desired location while housing circular clip 80 and pusher bar 93. Circular clip 80 is released by retracting hypodermic needle 90 from the pulled gastrointestinal wall while holding the clip 80 with pusher bar 93. After hypodermic needle 90 is fully retracted from the pulled gastrointestinal wall, pusher bar 93 is likewise retracted into collar 106. The pulled gastrointestinal wall is then released and clip 80 resumes its austenitic circular configuration as shown in Fig. 11D.

The mechanism by which hypodermic needle 90 and/or push bar 93 is advanced from or retracted into collar 106 is any suitable mechanism as is known in the art. For example, this mechanism can include a pulley and cable mechanism, a fluid pressure and piston mechanism, or a gear driven (e.g., rack and pinion) mechanism. A pulley and cable system, however, is preferred as it is the most simple of these systems.

The present invention provides a reliable, definitive treatment for the problem of gastrointestinal bleeding. Moreover, the present invention provides hemostatic clips that are deployable via natural body

orifices and without the manipulation of temperature. When deployed in accordance with the present invention, the clips provide sufficient strength to produce permanent hemostasis.

5 It will be obvious to those skilled in the art, having regard to this disclosure, that other variations on this invention beyond those specifically exemplified here may be made. Such variations are, however, to be considered as coming within the scope of this invention
10 as limited solely by the following claims.

Claims:

- 1 1. A hemostatic device, comprising:
2
3 a clip exhibiting pseudoelastic behavior at
4 body temperature;
5
6 wherein said clip is used to cause the
7 hemostasis of a blood vessel located along the
8 gastrointestinal tract.
- 1 2. The hemostatic device of claim 1, wherein said clip
2 comprises nitinol characterized by an A_s temperature
3 less than body temperature and an M_d temperature
4 greater than body temperature.
- 1 3. The hemostatic device of claim 2, wherein said clip
2 has a substantially U-shape configuration when said
3 nitinol is in a substantially austenitic phase, said U-
4 shape configuration comprising a first prong and a
5 second prong.
- 1 4. The hemostatic device of claim 3, wherein the
2 distance between said first and second prongs is
3 about 5-10 millimeters when said nitinol is in a
4 substantially austenitic state.
- 1 5. The hemostatic device of claim 2, wherein said clip
2 has a substantially circular configuration when said
3 nitinol is in a substantially austenitic state.
- 1 6. The hemostatic device of claim 5, wherein said clip
2 has an inner diameter of about 5-10 millimeters when
3 said nitinol is in a substantially austenitic state.
- 1 7. A method for causing the hemostasis of a blood
2 vessel located along the gastrointestinal tract,

3 said method comprising the steps of:
4
5 providing a clip exhibiting pseudoelastic
6 behavior at body temperature;
7
8 deforming said clip from a first configuration
9 to a second configuration;
10
11 delivering said clip to a target location along
12 the gastrointestinal tract, said delivering
13 occurring with the use of a delivery device
14 which holds said clip in said second
15 configuration; and
16
17 releasing said clip from said delivery device
18 such that said clip is urged toward said first
19 configuration, said clip thereby applying
20 sufficient constrictive forces to said blood
21 vessel to cause hemostasis thereof.

1 8. The method of claim 7, wherein said clip comprises
2 nitinol characterized by an A_s temperature less than
3 body temperature and an M_d temperature greater than
4 body temperature.

1 9. The method of claim 8, wherein said nitinol is in a
2 substantially austenitic state when in said first
3 configuration and said nitinol is in a substantially
4 stress-induced martensitic state when in said second
5 configuration.

1 10. The method of claim 7, wherein said step of
2 delivering occurs via a natural body orifice.

1 11. The method of claim 7, wherein said target location
2 is within about 1 centimeter of the blood vessel.

1 12. The method of claim 7, wherein:

2

3 said first configuration of said clip is
4 substantially U-shaped and comprises a first
5 prong and a second prong;

6

7 said second configuration of said clip is
8 substantially U-shaped and comprises a first
9 prong and a second prong, said first and second
10 prongs being further apart in said second
11 configuration than in said first configuration;
12 and

13

14 said delivery device comprises a hypotube for
15 holding said clip in said second configuration
16 during said delivering step, said hypotube
17 having a U-shaped configuration comprising a
18 first prong and a second prong, said first and
19 second prongs of said hypotube having pointed
20 ends.

1 13. The method of claim 12, further comprising the steps
2 of:

3

4 penetrating the gastrointestinal wall with said
5 pointed ends of said hypotube while said
6 hypotube holds said clip;

7

8 advancing said hypotube to a desired location
9 within the gastrointestinal wall; and

10

11 withdrawing said hypotube from the
12 gastrointestinal wall while holding said clip
13 at said desired location.

1 14. The method of claim 7, wherein:

2

3 said first configuration of said clip is
4 substantially circular;
5
6 said delivery device comprises
7
8 an endoscope;
9
10 a collar mounted on said endoscope;
11
12 a hypodermic needle having an arc
13 configuration and a pointed end, said
14 hypodermic needle being housed in said
15 collar; and
16
17 a tissue grasper extendable from said
18 endoscope; and
19
20 said deforming step comprises the step of
21 inserting said clip into said hypodermic needle
22 such that said second configuration of said
23 clip is an arc.

1 15. The method of claim 14, further comprising the steps
2 of:
3
4 grasping the gastrointestinal wall with said
5 tissue grasper;
6
7 pulling the gastrointestinal wall towards said
8 endoscope with said tissue grasper; and
9
10 penetrating the pulled gastrointestinal wall
11 with said hypodermic needle; and
12
13 advancing said hypodermic needle to a desired
14 location within the pulled gastrointestinal
15 wall.

1 16. The method of claim 15, wherein said releasing step
2 comprises the step of retracting said hypodermic
3 needle from the pulled gastrointestinal wall while
4 holding said clip at said desired location.

1 17. A method for causing the hemostasis of an ulcer bed
2 located along the gastrointestinal tract, said
3 method comprising the steps of:

4
5 providing a plurality of clips, each of said
6 clips exhibiting pseudoelastic behavior at body
7 temperature;

8
9 deforming each of said clips from a first
10 configuration to a second configuration;

11
12 delivering said plurality of clips to
13 respective target locations along the
14 gastrointestinal tract such that the ulcer bed
15 is substantially surrounded by said clips, said
16 delivering occurring with the use of a delivery
17 device which holds each of said clips in said
18 second configuration;

19
20 releasing each of said clips from said delivery
21 device such that each of said clips is urged
22 toward said first configuration.

1 18. The method of claim 17, wherein each of said clips
2 is within about 5 millimeters of said ulcer bed.

1 19. The method of claim 18, wherein each of said clips
2 is within about 1 millimeter of said ulcer bed.

1 20. The method of claim 17, wherein said delivery device
2 comprises:

3 an endoscope; and
4
5 a collar on said endoscope, wherein said collar
6 houses four clips such that a first pair of
7 clips are parallel to each other and a second
8 pair of clips are parallel to each other, said
9 first pair of clips being orthogonal to said
10 second pair of clips.

1 21. A system to achieve the hemostasis of a blood vessel
2 located along the gastrointestinal tract, said
3 system comprising:
4
5 a clip exhibiting pseudoelastic behavior at
6 body temperature; and
7
8 a delivery device.

1 22. The system of claim 21, wherein:
2
3 said clip has a first substantially U-shape
4 configuration when in a substantially
5 austenitic state, said first substantially U-
6 shape configuration comprising a first prong
7 and a second prong; and
8
9 said delivery device comprises an endoscope and
10 means for holding said clip in a second
11 substantially U-shaped configuration comprising
12 a first prong and a second prong, wherein the
13 distance between said first and second prongs
14 is greater in said second substantially U-
15 shaped configuration than in said first
16 substantially U-shaped configuration.

1 23. The system of claim 22, wherein:
2

3 said means for holding said clip in a second
4 substantially U-shaped configuration comprises
5 a hypotube having a U-shaped configuration
6 comprising a first prong and a second prong,
7 said first prong and said second prong of said
8 hypotube having pointed ends.

1 24. The system of claim 23, wherein said hypotube is
2 characterized by a longitudinal slot.

1 25. The system of claim 21, wherein:

2
3 said clip has a substantially circular
4 configuration when in a substantially
5 austenitic phase;

6
7 said delivery device comprises

8
9 an endoscope;

10
11 a collar mounted on said endoscope;

12
13 a hypodermic needle having an arc
14 configuration and a pointed end, said
15 hypodermic needle being housed in said
16 collar; and

17
18 a tissue grasper extendable from said
19 endoscope; and

20
21 said hypodermic needle holds said clip in an
22 arc configuration during insertion into the
23 gastrointestinal tract.

1 26. A system to achieve the hemostasis of an ulcer bed
2 located along the gastrointestinal tract, said
3 system comprising:

4 a plurality of clips exhibiting pseudoelastic
5 behavior at body temperature; and
6
7 a delivery device.

1 27. The system of claim 26, wherein:
2
3 said system comprises four clips; and
4
5 said delivery device comprises
6
7 an endoscope; and
8
9 a collar on said endoscope, wherein said
10 collar houses said clips such that a first
11 pair of clips are parallel to each other
12 and a second pair of clips are parallel to
13 each other, said first pair of clips being
14 orthogonal to said second pair of clips.

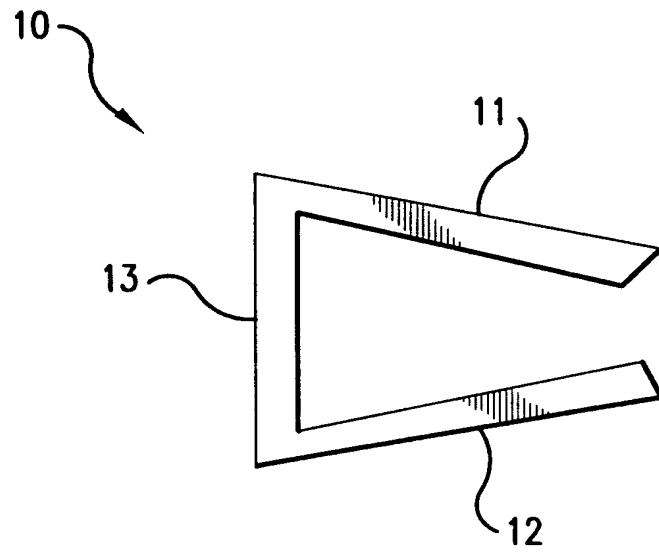

FIG. 1A

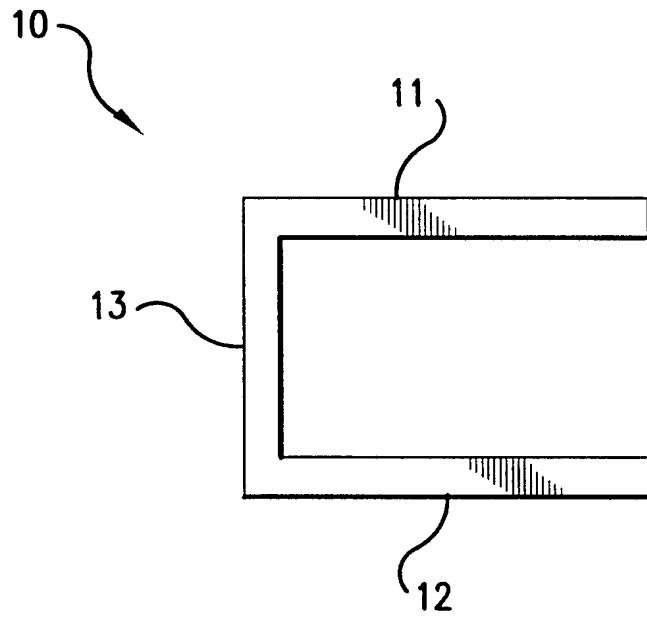

FIG. 1B

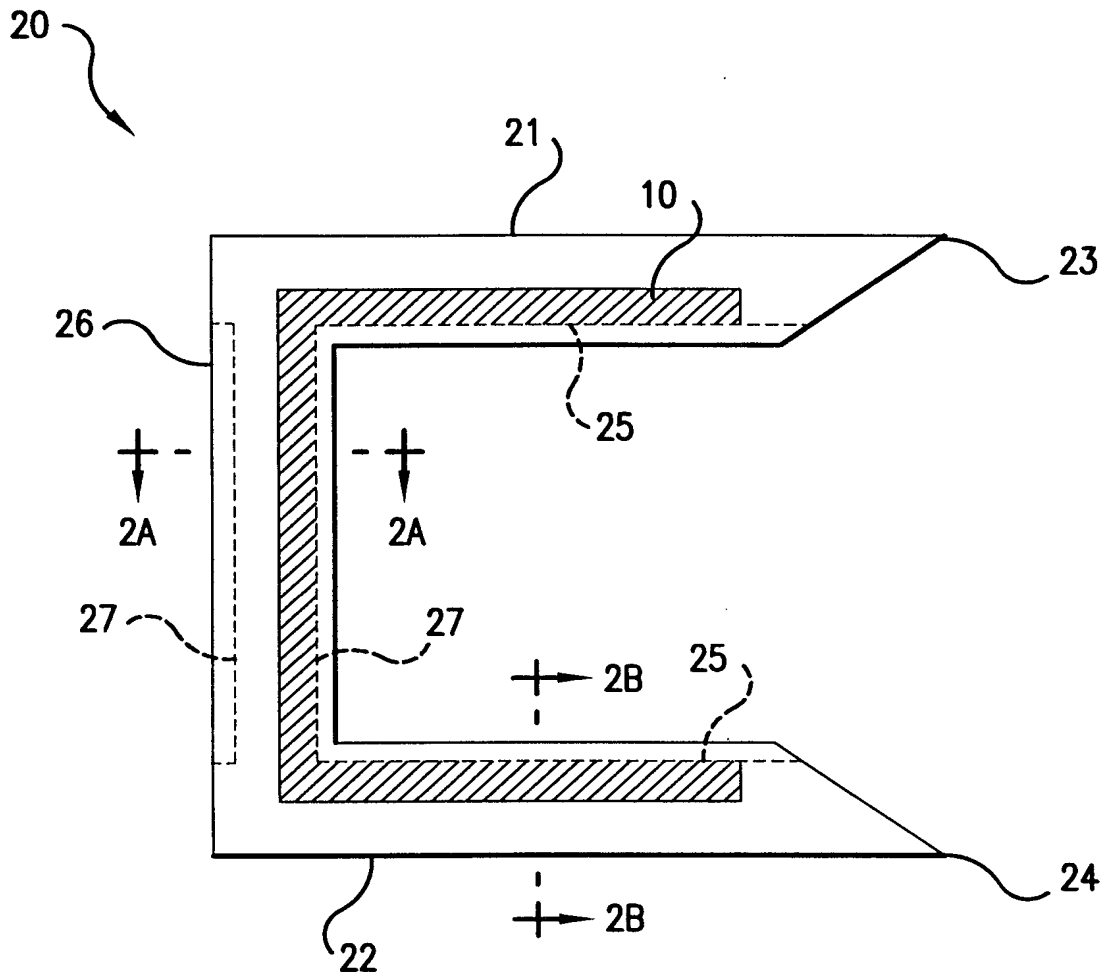

FIG. 2

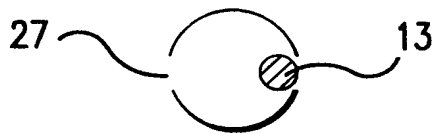

FIG. 2A

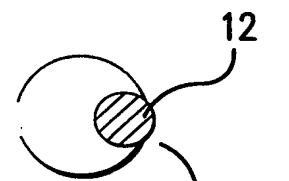

FIG. 2B

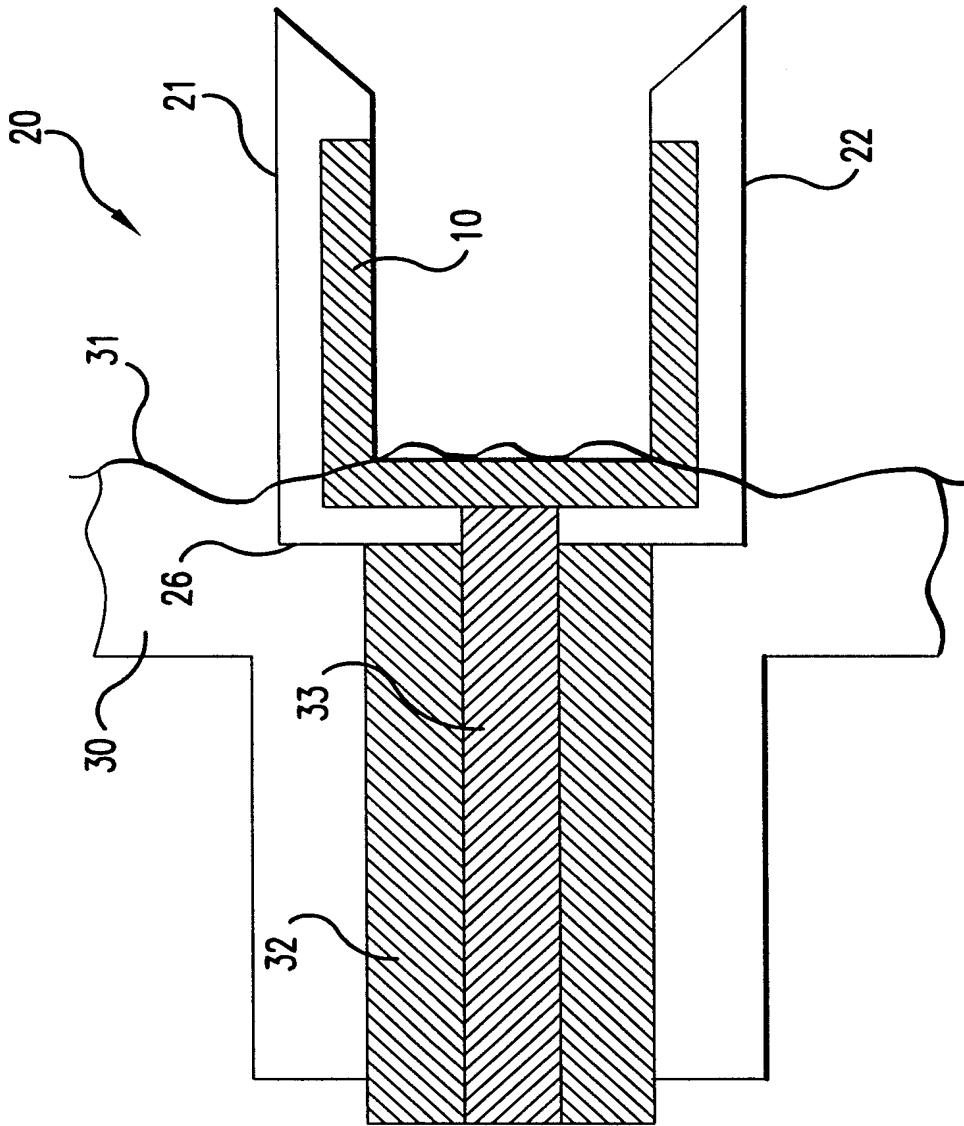

FIG.3

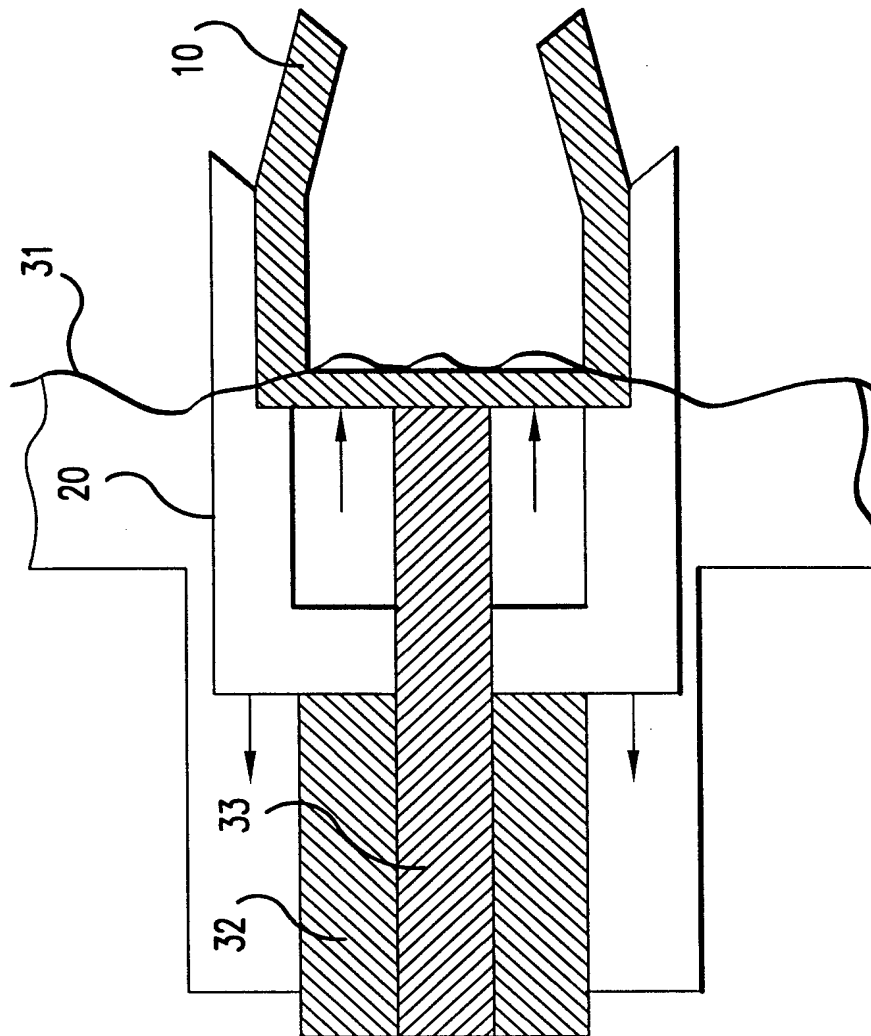

FIG.4

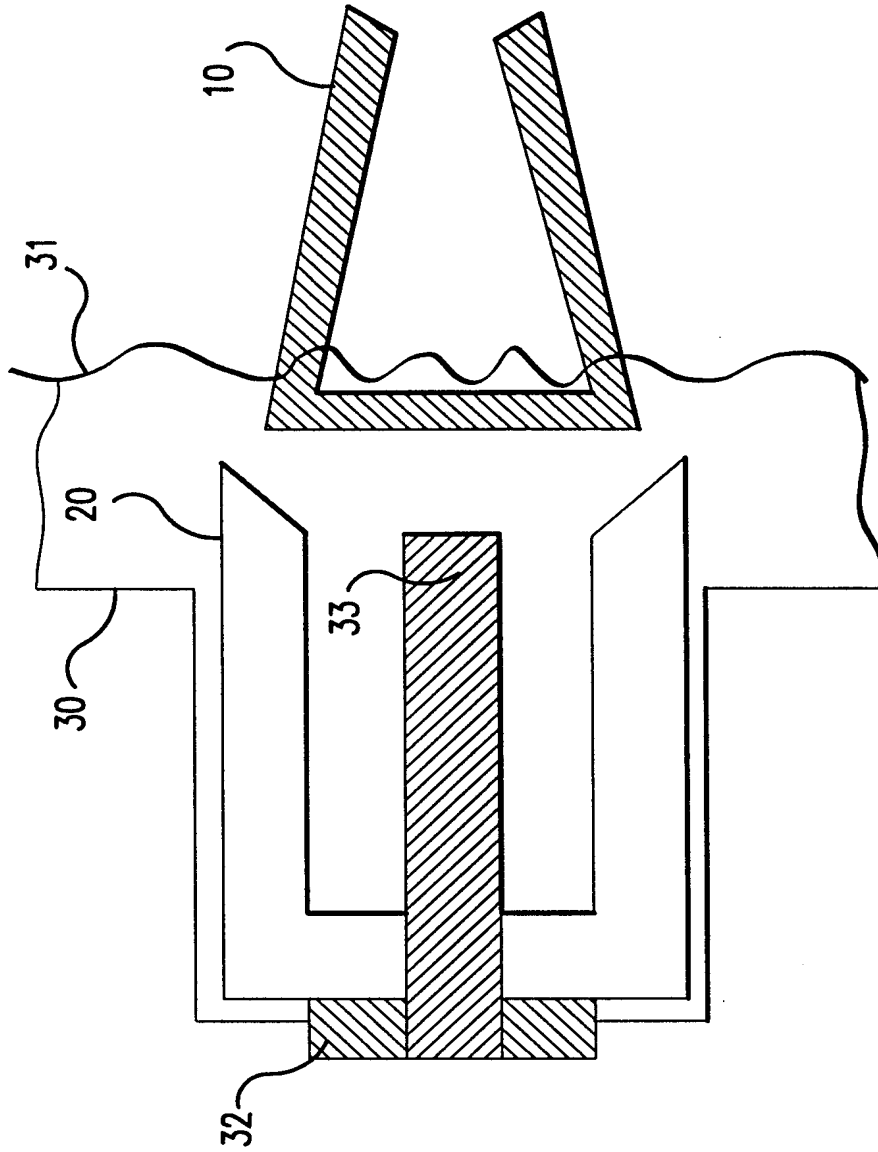

FIG.5

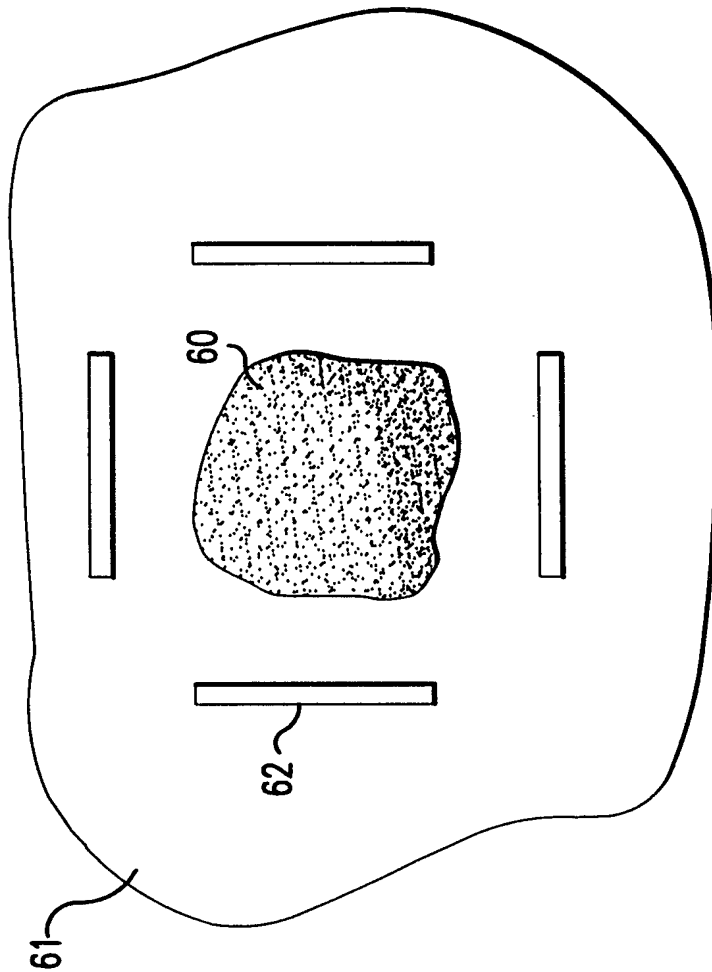

FIG. 6

7/12

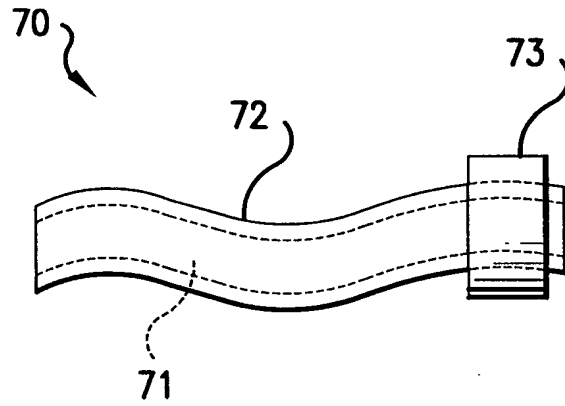

FIG. 7A

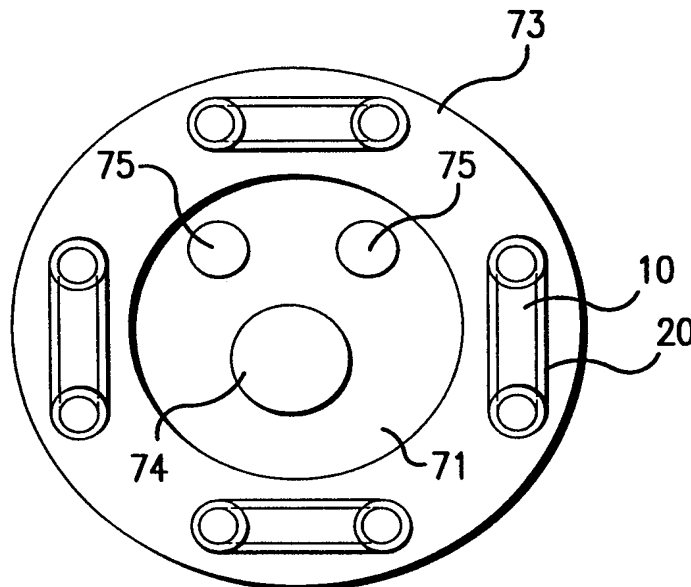

FIG. 7B

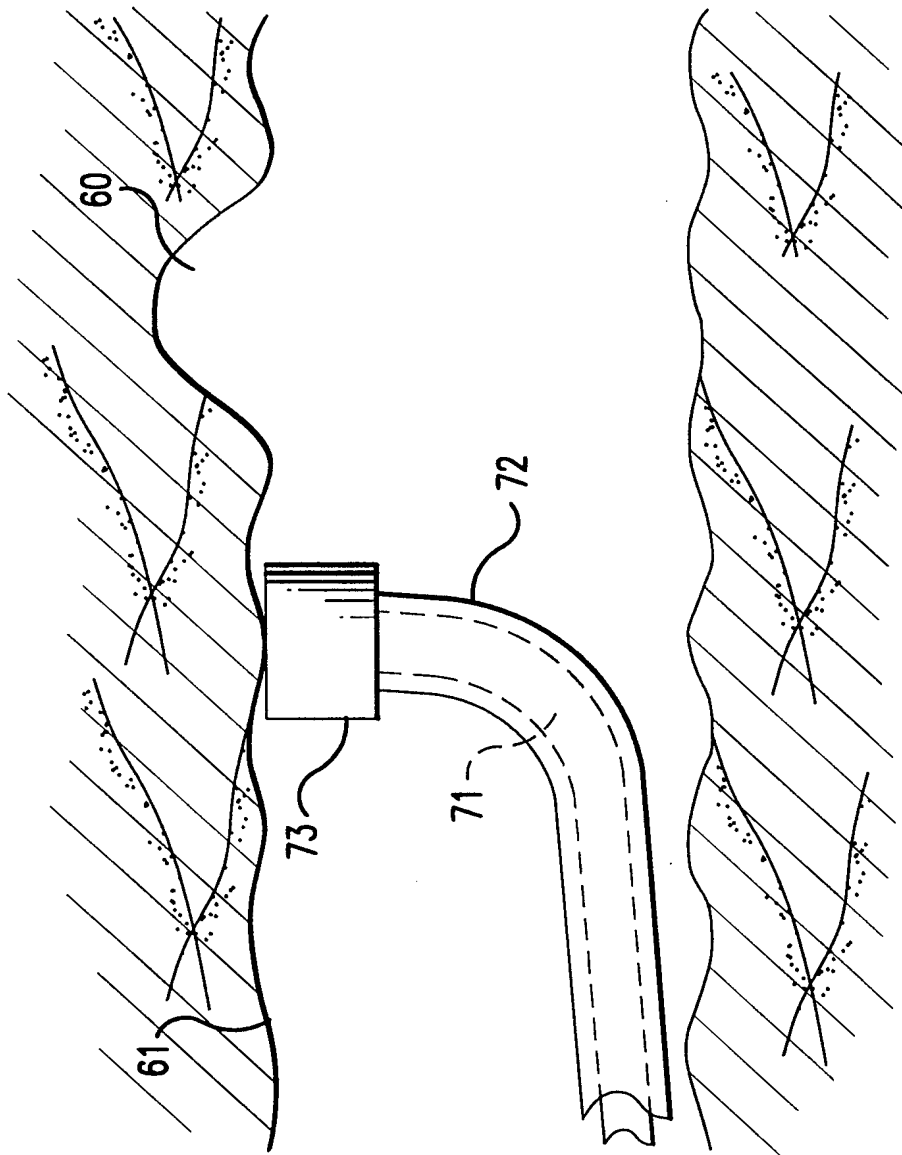

FIG.7C

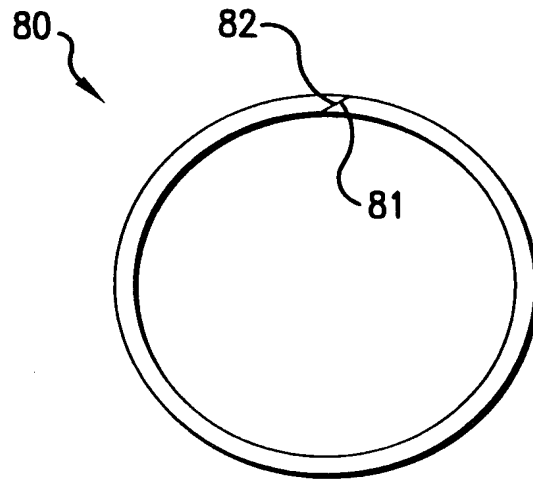

FIG. 8A

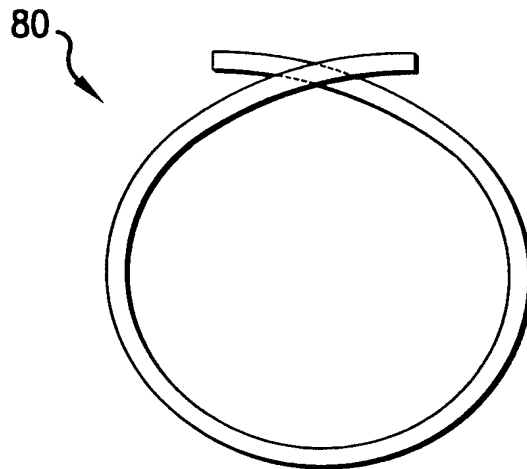

FIG. 8B

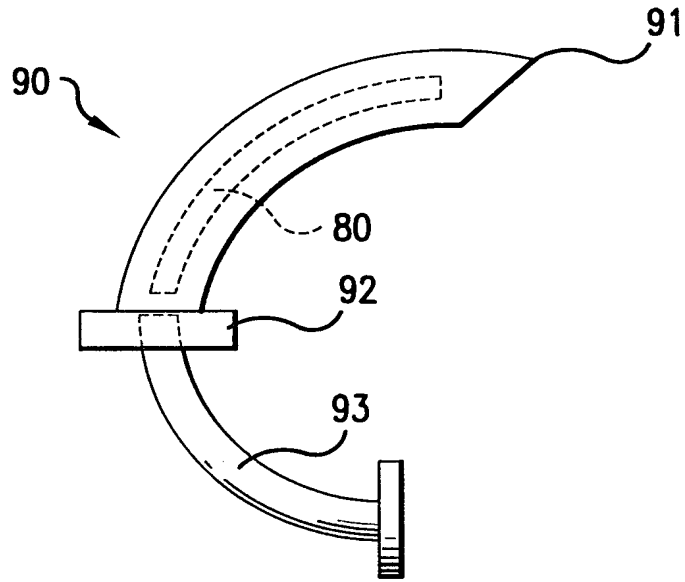

FIG. 9

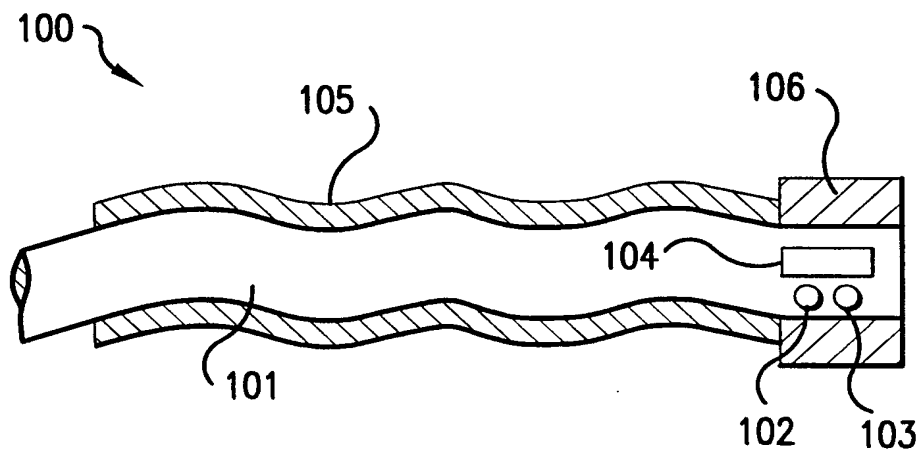

FIG. 10

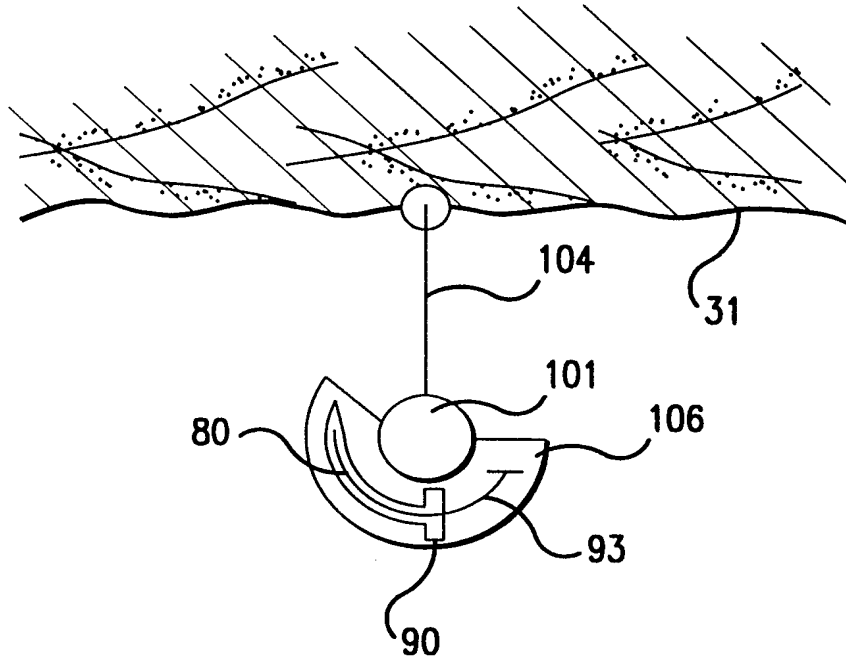

FIG. 11A

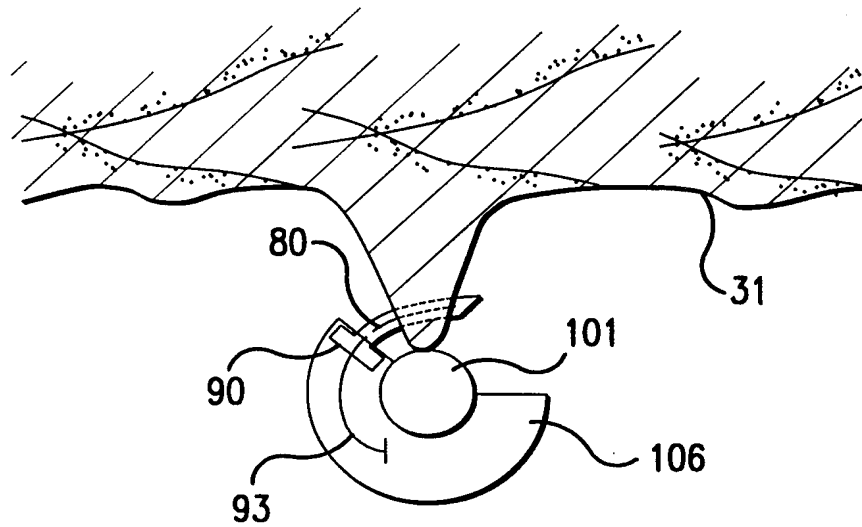

FIG. 11B

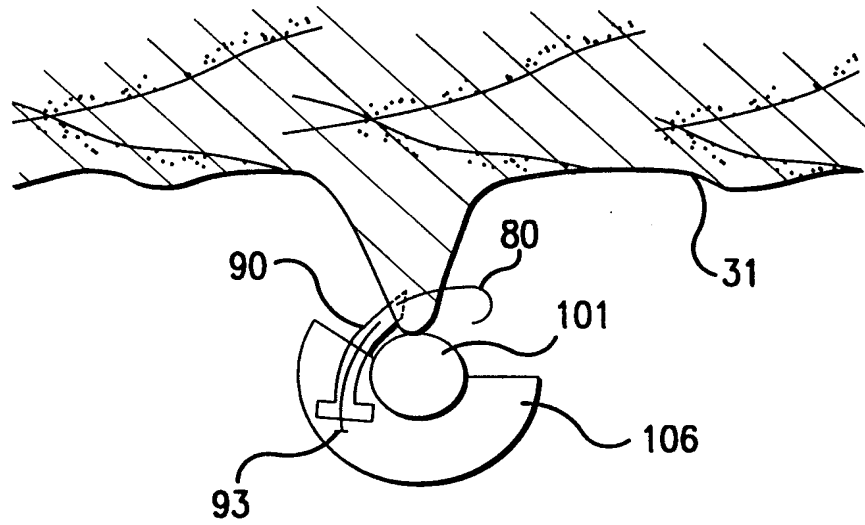

FIG. 11C

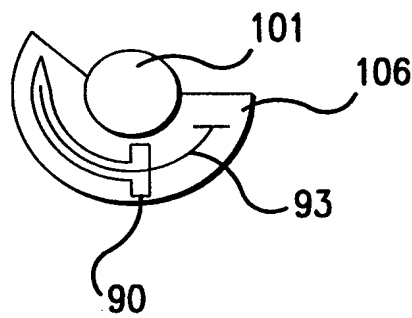
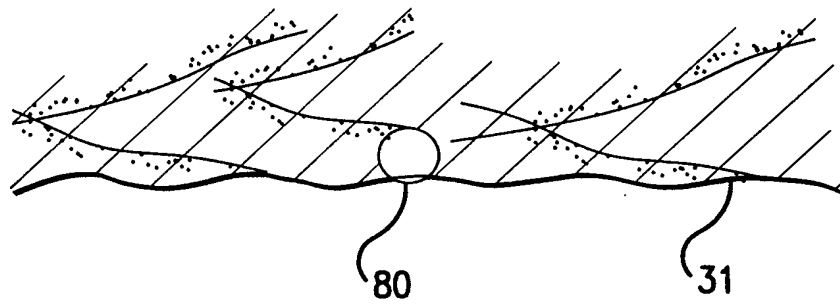

FIG. 11D

INTERNATIONAL SEARCH REPORT

Intern. Application No

PCT/US 98/12552

A. CLASSIFICATION OF SUBJECT MATTER
 IPC 6 A61B17/122 A61B17/128

According to International Patent Classification (IPC) or to both national classification and IPC

B. FIELDS SEARCHED

Minimum documentation searched (classification system followed by classification symbols)
 IPC 6 A61B

Documentation searched other than minimum documentation to the extent that such documents are included in the fields searched

Electronic data base consulted during the international search (name of data base and, where practical, search terms used)

C. DOCUMENTS CONSIDERED TO BE RELEVANT

Category	Citation of document, with indication, where appropriate, of the relevant passages	Relevant to claim No.
X	US 5 002 563 A (PYKA) 26 March 1991 cited in the application	1, 2, 5, 6, 21
Y	see claims 1, 4, 5	3, 4, 22
A	---	25
X	US 4 665 906 A (JERVIS) 19 May 1987 cited in the application see claims 3, 12	1, 21
X	US 5 632 746 A (MIDDLEMAN) 27 May 1997 see abstract; figures 2-12A, 2-12B see figures 2-14	1, 2, 5, 6, 21, 26
Y	US 4 485 816 A (KRUMME) 4 December 1984 cited in the application see figures 1, 3, 4	3, 4, 22
	--- -/--	

Further documents are listed in the continuation of box C.

Patent family members are listed in annex.

° Special categories of cited documents :

"A" document defining the general state of the art which is not considered to be of particular relevance

"E" earlier document but published on or after the international filing date

"L" document which may throw doubts on priority claim(s) or which is cited to establish the publication date of another citation or other special reason (as specified)

"O" document referring to an oral disclosure, use, exhibition or other means

"P" document published prior to the international filing date but later than the priority date claimed

"T" later document published after the international filing date or priority date and not in conflict with the application but cited to understand the principle or theory underlying the invention

"X" document of particular relevance; the claimed invention cannot be considered novel or cannot be considered to involve an inventive step when the document is taken alone

"Y" document of particular relevance; the claimed invention cannot be considered to involve an inventive step when the document is combined with one or more other such documents, such combination being obvious to a person skilled in the art.

"&" document member of the same patent family

Date of the actual completion of the international search

2 October 1998

Date of mailing of the international search report

12.10.98

Name and mailing address of the ISA
 European Patent Office, P.B. 5818 Patentlaan 2
 NL - 2280 HV Rijswijk
 Tel. (+31-70) 340-2040. Tx. 31 651 epo nl,
 Fax: (+31-70) 340-3016

Authorized officer

Barton, S

INTERNATIONAL SEARCH REPORT

Inter. Patent Application No

PCT/US 98/12552

C.(Continuation) DOCUMENTS CONSIDERED TO BE RELEVANT		
Category	Citation of document, with indication, where appropriate, of the relevant passages	Relevant to claim No.
A	WO 97 18762 A (INNOVASIVE) 29 May 1997 see figures 7,10,26,39-42 -----	22,23,25
A	US 4 696 300 A (ANDERSON) 29 September 1987 see figure 7 -----	22,23
A	US 4 586 502 A (BEDI) 6 May 1986 see figure 2B -----	25
A	US 5 258 008 A (WILK) 2 November 1993 see abstract; claim 8 -----	22,25,27
P,X	EP 0 826 340 A (MEDINOV) 4 March 1998 see abstract; figures 3,6-9 -----	1-4,21, 22

INTERNATIONAL SEARCH REPORT

International application No.
PCT/US 98/12552

Box I Observations where certain claims were found unsearchable (Continuation of item 1 of first sheet)

This International Search Report has not been established in respect of certain claims under Article 17(2)(a) for the following reasons:

1. Claims Nos.: 7-20
because they relate to subject matter not required to be searched by this Authority, namely:
Rule 39.1(iv) PCT - Method for treatment of the human or animal body by surgery
2. Claims Nos.:
because they relate to parts of the International Application that do not comply with the prescribed requirements to such an extent that no meaningful International Search can be carried out, specifically:
3. Claims Nos.:
because they are dependent claims and are not drafted in accordance with the second and third sentences of Rule 6.4(a).

Box II Observations where unity of invention is lacking (Continuation of item 2 of first sheet)

This International Searching Authority found multiple inventions in this international application, as follows:

see additional sheet

1. As all required additional search fees were timely paid by the applicant, this International Search Report covers all searchable claims.
2. As all searchable claims could be searched without effort justifying an additional fee, this Authority did not invite payment of any additional fee.
3. As only some of the required additional search fees were timely paid by the applicant, this International Search Report covers only those claims for which fees were paid, specifically claims Nos.:
4. No required additional search fees were timely paid by the applicant. Consequently, this International Search Report is restricted to the invention first mentioned in the claims; it is covered by claims Nos.:

Remark on Protest

- The additional search fees were accompanied by the applicant's protest.
- No protest accompanied the payment of additional search fees.

FURTHER INFORMATION CONTINUED FROM PCT/ISA/ 210

This International Searching Authority found multiple (groups of) inventions in this international application, as follows:

1. Claims: 1-4,21-24

u-shaped pseudoelastic clip and system adapted to its delivery

2. Claims: 1,5,6,21,25

circular pseudoelastic clip and system adapted to its delivery

3. Claims: 21,26,27

system for placing an array of pseudoelastic clips

INTERNATIONAL SEARCH REPORT

Information on patent family members

Inter. Patent Application No

PCT/US 98/12552

Patent document cited in search report	A	Publication date	Patent family member(s)	Publication date
US 5002563	A	26-03-1991	AT 132027	T 15-01-1996
			CA 2076672	A 23-08-1991
			DE 69115892	D 08-02-1996
			DE 69115892	T 05-09-1996
			EP 0516720	A 09-12-1992
			WO 9112771	A 05-09-1991
			<hr style="border-top: 1px dashed black;"/>	
US 4665906	A	19-05-1987	US 5190546	A 02-03-1993
			US 5597378	A 28-01-1997
			CA 1246956	A 20-12-1988
			EP 0145166	A 19-06-1985
			JP 2543328	B 16-10-1996
			JP 7067951	A 14-03-1995
			JP 2715377	B 18-02-1998
			JP 60100956	A 04-06-1985
			US 5067957	A 26-11-1991
<hr style="border-top: 1px dashed black;"/>				
US 5632746	A	27-05-1997	US 5486183	A 23-01-1996
			US 5509923	A 23-04-1996
			US 5749879	A 12-05-1998
			US 5601572	A 11-02-1997
			US 5720754	A 24-02-1998
			AU 664358	B 16-11-1995
			AU 8918191	A 28-04-1992
			CA 2093821	A 10-04-1992
			EP 0554361	A 11-08-1993
			JP 6502354	T 17-03-1994
			WO 9205828	A 16-04-1992
			AT 131370	T 15-12-1995
			CA 2064830	A 17-02-1991
			DE 69024219	D 25-01-1996
			DE 69024219	T 07-11-1996
			EP 0487645	A 03-06-1992
JP 4507363	T 24-12-1992			
WO 9102493	A 07-03-1991			
<hr style="border-top: 1px dashed black;"/>				
US 4485816	A	04-12-1984	NONE	
<hr style="border-top: 1px dashed black;"/>				
WO 9718762	A	29-05-1997	AU 1055797	A 11-06-1997
<hr style="border-top: 1px dashed black;"/>				

INTERNATIONAL SEARCH REPORT

Information on patent family members

Inter. Application No

PCT/US 98/12552

Patent document cited in search report	Publication date	Patent family member(s)	Publication date
US 4696300 A	29-09-1987	US 4736746 A	12-04-1988
US 4586502 A	06-05-1986	NONE	
US 5258008 A	02-11-1993	US 5441507 A	15-08-1995
		US 5330486 A	19-07-1994
EP 826340 A	04-03-1998	FR 2752720 A	06-03-1998